

THE AMERICAN MATHEMATICAL MONTHLY
Volume 106, Number 3, May 1999

Julian Solov	Algebra and the Mordell Conjecture	163
Arnold J. Garsz	The Riemann Hypothesis and Mertens' Formula	169
Gregory B. Sargsyan	Combinatorics of Catalan Numbers	173
Thomas M. Rassias	A Tale of Two Integrals	227
John P. Franco	A Mathematical Excursion from the Riemann Hypothesis to a Catalan Number	241
NOTES		
Paul W. Lewis	An Algebraic Approach to the Conjecture of Erdős and Székeres	253
Bernard K. Selig	Getting a Function into the Range of a Function	257
Robert J. Dilworth	A Short Proof of Erdős' Theorem on the Structure of the Set of Integers	261
THE EQUATION OF		
J. S. G. G. G.	The Linear Equation of First and Second Order	265
PROBLEMS		
Richard P. Stanley	An Asymptotic to Higher Mathematics	271
John H. Conway	On the Structure of the Group of Automorphisms of a Free Group	275
Richard P. Stanley	Algebraic Combinatorics: A Survey	279
Richard P. Stanley	The Algebra of Invariants: A Survey	283
Richard P. Stanley	Combinatorics and Probability	287
TELEPHONE		
EDITORIAL BOARD		

The American Mathematical Monthly

ISSN: 0002-9890 (Print) 1930-0972 (Online) Journal homepage: <https://www.tandfonline.com/loi/uamm20>

A Tale of Two Integrals

Vilmos Totik

To cite this article: Vilmos Totik (1999) A Tale of Two Integrals, The American Mathematical Monthly, 106:3, 227-240, DOI: [10.1080/00029890.1999.12005033](https://doi.org/10.1080/00029890.1999.12005033)

To link to this article: <https://doi.org/10.1080/00029890.1999.12005033>



Published online: 23 Apr 2018.



Submit your article to this journal [↗](#)



Article views: 12



View related articles [↗](#)

A Tale of Two Integrals

Vilmos Totik

1 THE PROBLEM. We present several approaches to a simple-looking but highly nontrivial combinatorial-analysis problem. Our aim is to show how different ideas can lead to a solution.

The problem is easy to state: *Let f and g be two integrable functions on $[0, 1]$ with*

$$\int_0^1 f = \int_0^1 g = 1. \tag{1}$$

Show that there is some interval $I \subset [0, 1]$ such that

$$\int_I f = \int_I g = \frac{1}{2}. \tag{2}$$

Instead of $[0, 1]$ we could have any interval, and f and g need not have integrals equal to 1; the general statement is that there is always a single interval where each function has integral equal to one half of its total integral.

Here is an equivalent formulation without integrals: *On a blackjack machine one can win or lose one dollar at a time. Suppose two players playing once per minute during a period find that eventually both of them win exactly $2N$ dollars. Show that there was a time interval during which both of them won exactly N dollars.*

We sketch the equivalence of the two forms. The second form is a consequence of the first if we apply it to some appropriate step functions f and g with values ± 1 modelling the outcome of the blackjack games (see Figure 1). Then there is an interval (a, b) over which both f and g have integral N . If both a and b are integers, then going back to the blackjack game we get a time interval with the desired properties. If they are not, then with some $0 < \alpha < 1$ we have $a = [a] + \alpha$

outcome of the game:

first player	second player
+ - - + + - + +	+ - + + + - - +

the associated functions:

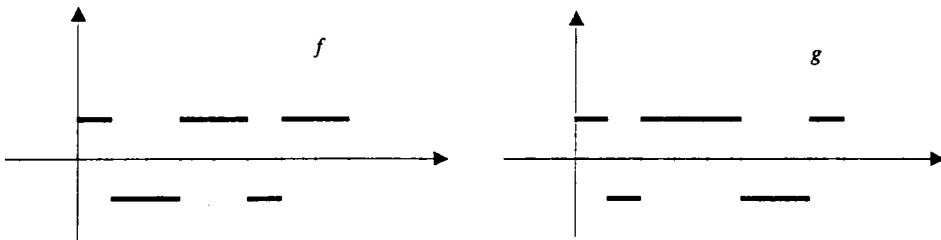

Figure 1. The equivalence of the two formulations

and $b = [b] + \alpha$. If $\alpha \neq \frac{1}{2}$, then the integrals of f and g over $([a], [b])$ are again equal to N , so we are back at the integer case. This is also true if $\alpha = \frac{1}{2}$ and both functions have the same sign at a and b . Finally, if $\alpha = \frac{1}{2}$ and one of them has different signs at a and b , then a simple parity argument (based on the fact that two sums of the form $\sum_{k=1}^m \pm 1$ are equal or differ by an even integer) shows that the same is true of the other function, and then the integrals over $([a] + 1, [b])$ are again N .

In the opposite direction suppose the blackjack statement is true, and let f and g be two functions satisfying (1). We can assume (see below) f and g to be bounded, say $|f| \leq M$, $|g| \leq M$. Then the graphs of the functions

$$\frac{1}{M} \int_0^x f \quad \text{and} \quad \frac{1}{M} \int_0^x g$$

can be arbitrarily well approximated by piecewise linear curves with equidistant nodes and slopes ± 1 . Now the slope functions of these curves can be regarded as the outcome of blackjack games for two players ($+1$ stands for winning and -1 for losing a dollar), so the second formulation can be applied. Going from here to (2) is a routine limiting process to be discussed below.

We shall adhere to the first formulation, though the precise notion of “integral” is irrelevant. In fact, the problem is not easier if we assume that f and g are continuous, or that they are step functions. To see this it is enough to note the following. Suppose that f_n and g_n are functions satisfying (1) such that

$$\int_0^1 |f_n - f| \rightarrow 0 \quad \text{and} \quad \int_0^1 |g_n - g| \rightarrow 0,$$

and suppose we can verify the existence of intervals $I_n = (a_n, b_n)$ satisfying (2) for the pairs f_n, g_n . By selecting a subsequence N_1 of the natural numbers for which $\{a_n\}_{n \in N_1}$ and $\{b_n\}_{n \in N_1}$ converge to some a and b , we can show that (2) holds for $I = (a, b)$. Thus, without loss of generality we may assume that f and g belong to any chosen dense subspace of the space of integrable functions, for example the space of continuous functions or the space of step functions.

We present several solutions to the problem that are related to other combinatorial or geometrical/topological results. Some of these solutions are genuinely different, some are interrelated, but all of them use some well known facts of mathematics. Other approaches are also known, but none of the elementary solutions (that mainly use induction) I know is short enough to present in one or two pages.

The problem appeared on the 1995 Miklós Schweitzer Mathematical Contest in Hungary. This is a unique mathematical contest organized every fall since 1949 by the János Bolyai Mathematical Society. It is a contest for university students and fresh graduates, but sometimes talented high school students also successfully participate. About a dozen problems (almost exclusively new) are proposed from different branches of mathematics, and the students have 10 days to solve them using all available literature. Accordingly, the problems are considerably more difficult than on other mathematical competitions and olympiads. The problems and solutions from the contests in the years 1962–1991 have been published in the Springer Problem Book series: *Contests in Higher Mathematics*, Ed. G. J. Székely, 1995.

The problem is more difficult than one might expect. In fact, the very first thought, namely continuously move the endpoints a and b of $I = (a, b)$, leads to

big obstacles. The argument would run like this: there is an a_0 such that for each $0 \leq a \leq a_0$ there is a b_a with $\int_a^{b_a} f = \frac{1}{2}$. If $\int_0^{b_0} g = \frac{1}{2}$, then we are done. If, say, $\int_0^{b_0} g < \frac{1}{2}$, then we must have $\int_{b_0}^1 g > \frac{1}{2}$. Therefore if we continuously move a from 0 to b_0 , there will be a value of a for which the integral $\int_a^{b_a} g$ is exactly $\frac{1}{2}$, and so $I = (a, b_a)$ is suitable. The problem with this reasoning is that b_a does not depend continuously on a , and the whole argument collapses. Even worse than that, in general there is no continuous function $b(a)$ such that

$$\int_a^{b(a)} f = \frac{1}{2} \tag{3}$$

for all $a \in [0, a_0]$ (see Figure 2). Thus, the preceding reasoning cannot be rectified.

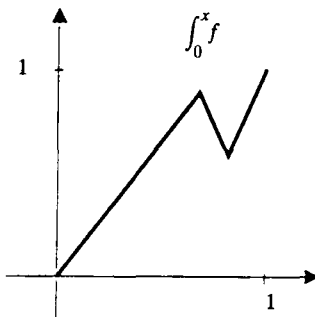

Figure 2. No continuous $b(a)$ exists

This simple continuity argument does work if f is strictly positive, for then there is a single $b(a)$ satisfying (3), and the function $b(a)$ is continuous. By adding ϵ to f and then letting $\epsilon \rightarrow 0$ we can conclude that the same is true for nonnegative f . Let us also mention that for piecewise constant f there are continuous functions $a(t)$, $b(t)$ on the parameter interval $[0, 1]$ such that

$$\int_{a(t)}^{b(t)} f = \frac{1}{2}, \tag{4}$$

$a(0) = 0$, $a(1) = b(0)$, and $b(1) = 1$, so a continuity argument like the one before can be applied. However, proving the existence of $a(t)$ and $b(t)$ is as difficult as the original problem.

2 THE BORSUK-ULAM ANTIPODAL THEOREM. The Borsuk-Ulam Theorem [1, p. 241] states that if $T : S^2 \rightarrow \mathbf{R}^2$ is a continuous mapping of S^2 (the unit sphere in \mathbf{R}^3) into the plane, then there exists a pair of antipodal points $\{X, -X\}$ of S^2 that have the same image: $T(X) = T(-X)$. If T is also odd, i.e., $T(-Y) = -T(Y)$ for all $Y \in S^2$, then we must have $T(X) = (0, 0)$. The same is true in higher dimensions, namely if $T : S^l \rightarrow \mathbf{R}^l$ is a continuous mapping of the unit sphere in \mathbf{R}^{l+1} , then there exists a pair of antipodal points $\{X, -X\}$ on S^l that have the same image.

Using the Borsuk-Ulam Theorem, the solution of our problem is easy. Let (ξ_1, ξ_2, ξ_3) , $\xi_1^2 + \xi_2^2 + \xi_3^2 = 1$ be a point on S^2 , and let

$$T(\xi_1, \xi_2, \xi_3) = (X(f; \xi_1, \xi_2, \xi_3), X(g; \xi_1, \xi_2, \xi_3)),$$

where

$$X(f; \xi_1, \xi_2, \xi_3) = \text{sign}(\xi_1) \int_0^{\xi_1^2} f + \text{sign}(\xi_2) \int_{\xi_1^2}^{\xi_1^2 + \xi_2^2} f + \text{sign}(\xi_3) \int_{\xi_1^2 + \xi_2^2}^1 f. \tag{5}$$

Since T is a continuous odd mapping of S^2 into the plane, the Borsuk–Ulam theorem ensures that some point $(\xi_1^*, \xi_2^*, \xi_3^*)$ is mapped into $(0, 0)$ by T . Among the numbers $\xi_1^*, \xi_2^*, \xi_3^*$, two have the same sign (consider 0 to be of positive sign). If the third number is ξ_j^* , and I denotes the interval of length ξ_j^* in the integral multiplied by sign (ξ_j^*) in (5), then from the definition of T and from $T(\xi_1^*, \xi_2^*, \xi_3^*) = (0, 0)$ it follows that

$$\int_I f = \int_{[0,1] \setminus I} f \quad \text{and} \quad \int_I g = \int_{[0,1] \setminus I} g.$$

The claim follows with this I if we also take into account the conditions $\int_0^1 f = \int_0^1 g = 1$.

The Borsuk–Ulam theorem is a standard tool in solving the following necklace of pearls problem. *Two pirates have a single-strand necklace containing $2k$ black pearls and $2k$ white pearls arranged in any order. They would like to cut the necklace into as few pieces as possible so that after dividing the pieces of the necklace between them, each gets exactly k white pearls and k black ones.* An easy modification of the preceding solution permits us to conclude that two cuts are always enough (i.e., there is always a sequence of $2k$ consecutive pearls on the necklace that contains k pearls of each type). This is related to the case of our original problem where both functions (representing the two types of pearls on intervals of equal lengths, see Figure 3) are nonnegative; hence we do not need the antipodal theorem, as

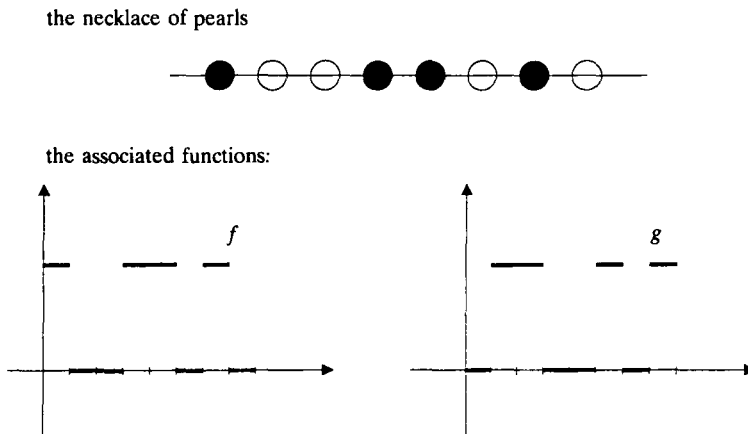

Figure 3. Reduction of the pearl problem

the solution follows by a simple continuity argument. If the necklace contains l types of pearls, and there are $2k$ pearls of each type, we can apply the higher dimensional version of the Borsuk–Ulam theorem to show that l cuts are always enough.

In a similar manner, by applying the antipodal theorem in higher dimensions we get the following generalization of our original problem due to A. Pinkus: *if $f_1, \dots, f_l \in L^1[0, 1]$ and $\int_0^1 f_j = 1$ for all $j = 1, \dots, l$, then there is a set I consisting of at most $(l + 1)/2$ intervals such that $\int_I f_j = \frac{1}{2}$ for all $j = 1, \dots, l$.*

3 THE MOUNTAIN CLIMBING PROBLEM. Can two climbers climb up opposite sides of a mountain to the top in such a way that both of them are always at the same altitude (see [7] and [9])? There are some obvious obstacles that prevent

them from doing so, however, the answer is YES if the sides of the mountain are piecewise linear curves and the climbers start at the bottom [6]. We show that this result implies a solution to our problem.

Assume, as we may, that both f and g are piecewise constant. Then

$$H(x) = \int_0^x (f(u) - g(u)) du$$

is piecewise linear, and $H(0) = H(1)$, so we can extend H to a continuous 1-periodic function. Let us also extend f and g periodically to \mathbf{R} with period 1. The graph of H is our “mountain” (see Figure 4), and two climbers climb from the

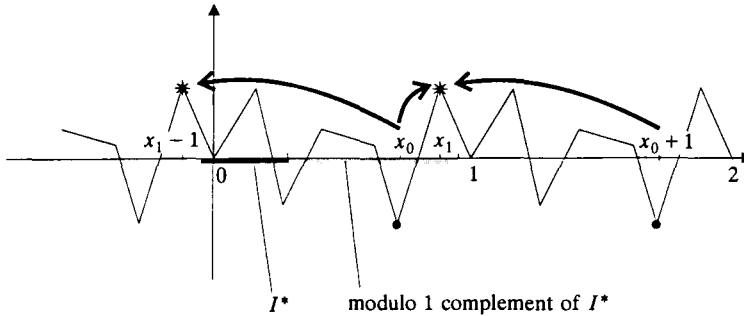

Figure 4. The mountain of the two climbers

bottom level of that mountain, say from the points x_0 and $x_0 + 1$, to one of the maximum points of H in $[x_0, x_0 + 1]$, say to the peak at x_1 . According to [6] they can do so and stay always at the same level. Now by the periodicity, we can assume that both climbers start at x_0 , the first one climbs to the right to the peak at x_1 , while the second one climbs to the left to the peak at $x_1 - 1$. Let the x coordinate of the two climbers at time $t \in [0, 1]$ be $\gamma_1(t)$ and $\gamma_2(t)$. Thus, the γ_j are continuous functions such that $\gamma_1(0) = \gamma_2(0) = x_0$, $\gamma_1(1) = x_1$, $\gamma_2(1) = x_1 - 1$, and at every moment $\gamma_2(t) \leq x_0 \leq \gamma_1(t)$. Since the climbers always stay at the same altitude, we have

$$\int_{\gamma_2(t)}^{\gamma_1(t)} f(u) du = \int_{\gamma_2(t)}^{\gamma_1(t)} g(u) du. \quad (6)$$

However, the left integral is zero for $t = 0$, is 1 for $t = 1$ since $[\gamma_2(1); \gamma_1(1)] = [x_1 - 1, x_1]$ is a full period for f , and is a continuous function of t , so there is a $t = t^*$ for which the left-hand side is equal to $\frac{1}{2}$. But then the right hand side is also $\frac{1}{2}$, which means that for $I^* = [\gamma_2(t^*), \gamma_1(t^*)]$ we have

$$\int_{I^*} f = \int_{I^*} g = \frac{1}{2}.$$

This seems to be what we are looking for, but we have to be careful, for the interval I^* may not belong to $[0, 1]$ (or for that matter to some $[n, n + 1]$ with integer n). If it does, then we just set $I = I^*$. If not, then we can take as I its complement in $[0, 1]$ modulo 1 (see Figure 4), which, in view of (1), satisfies (2).

This solution yields the following generalization. *Let f and g be integrable functions on $[0, 1]$ satisfying (1), and let $0 < \alpha < 1$. If there is no interval $I \subset [0, 1]$*

with

$$\int_I f = \int_I g = \alpha,$$

then there is an interval I with

$$\int_I f = \int_I g = 1 - \alpha. \quad (7)$$

Our proof gives $I = I^*$ for α if $I^* \subset [0, 1]$; if $I^* \not\subset [0, 1]$, then its modulo 1 complement is suitable for I in (7).

Thus, for any given $\alpha \in (0, 1)$, there is always an interval I where the integrals of both f and g equal either α or $1 - \alpha$. For $\alpha = \frac{1}{2}$ this means that both f and g have integrals $\frac{1}{2}$, as is claimed in the problem. For $\alpha = \frac{1}{3}$ there is an interval I such that either both functions have integral $\frac{1}{3}$ on I , or both of them have integral $\frac{2}{3}$. In the latter case we can apply the already proven $\frac{1}{2}$ -case to I , and conclude that on some subinterval of I both functions have integral equal to $(2/3)/2 = \frac{1}{3}$. Thus, there is an interval with both integrals equal to $\frac{1}{3}$. This argument can be repeated, to obtain an interval over which both integrals equal any given value $\frac{1}{4}, \frac{1}{5}, \dots$. This is a generalization of the original problem: *Let f and g be two integrable functions on $[0, 1]$ satisfying (1) and let k be a positive integer. Then there is an interval I such that*

$$\int_I f = \int_I g = \frac{1}{k} \quad (8)$$

This is false for every $\alpha \in (0, 1)$ that is not of the form $\alpha = 1/k$. In fact, if $f(x) = (2n + 1)/(n + 1)$ if $2k/(2n + 1) \leq x \leq (2k + 1)/(2n + 1)$ ($k = 0, 1, \dots, n$) and 0 otherwise, and if $g(x) = (2n + 1)/n$ if $(2k - 1)/(2n + 1) \leq x \leq 2k/(2n + 1)$ ($k = 1, 2, \dots, n$) and 0 otherwise, then for no $\alpha \in ((n + 1)^{-1}, n^{-1})$ is there an interval I for which

$$\int_I f = \int_I g = \alpha$$

(see Figure 5 where the $n = 1$ case is displayed).

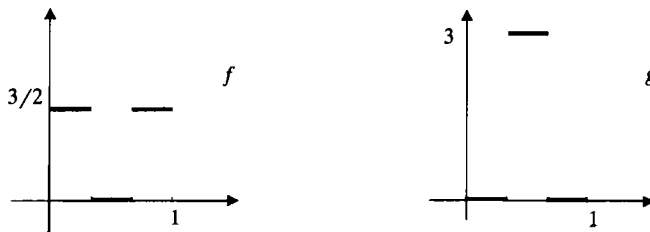

Figure 5. No common intervals for $\frac{1}{2} < \alpha < 1$

4 THE CHORD THEOREM. The chord theorem [3, pp. 21 and 198–199] states that if γ is a continuous curve on the plane with endpoints A and B , then for every positive integer k there is a chord \overline{CD} of γ (i.e., $C, D \in \gamma$) that is parallel to \overline{AB} and has length $1/k$ times the length of \overline{AB} .

Apply the chord theorem to the curve

$$\gamma(t) := \left(\int_0^t f(u) du, \int_0^t g(u) du \right), \quad t \in [0, 1]$$

with $k = 2$. Since γ has endpoints $(0, 0)$ and $(1, 1)$, it has a chord of the form $(X, Y)(X + \frac{1}{2}, Y + \frac{1}{2})$, i.e., if we choose parameters $t_1, t_2 \in [0, 1]$ such that $\gamma(t_1) = (X, Y)$ and $\gamma(t_2) = (X + \frac{1}{2}, Y + \frac{1}{2})$, then

$$\int_{t_1}^{t_2} f(u) du = \int_{t_1}^{t_2} g(u) du = \frac{1}{2}, \tag{9}$$

and we seem to have solved the problem. However, I. Z. Ruzsa observed that we might have $t_2 < t_1$, i.e., if I is the interval determined by the parameters t_1 and t_2 (which is $[t_2, t_1]$ for $t_2 < t_1$), then (9) means that on I both functions have integral $-\frac{1}{2}$, instead of $\frac{1}{2}$, so the chord theorem does not give us what we want.

Our approach via the chord theorem can be saved as follows. Assume, as we may, that f and g are piecewise constant functions that do not vanish on any subinterval. Select a maximal subinterval $J_1 \subset [0, 1]$ such that the integrals of f and g over J_1 are equal, and the common value of the integrals is either zero or a positive integer multiple of $-\frac{1}{2}$. Then select a maximal subinterval $J_2 \subset [0, 1]$ disjoint from J_1 such that the integrals of f and g over J_2 are equal, and the common value of these integrals is either zero or a positive integer multiple of $-\frac{1}{2}$. Continue this process by always selecting maximal subintervals that are disjoint from all previously selected subintervals. We claim that this process must terminate in finitely many steps. If not, then there was an infinite family of disjoint subintervals over which the integral of f is zero or a positive integer multiple of $-\frac{1}{2}$. That the integral cannot be a positive multiple of $-\frac{1}{2}$ for infinitely many disjoint subintervals is clear. Hence, there are infinitely many disjoint intervals over which f has zero integrals. However, this is again impossible, because every such interval must contain a discontinuity point of f ; recall that f is piecewise constant with nonzero function values.

Let the selected maximal intervals be J_1, \dots, J_m . Contract each of the J_k 's to a single point (see Figure 6). We obtain an interval $[0, a]$, an integer $k \geq 2$, and two functions f^* and g^* such that

$$\int_0^a f^* = \int_0^a g^* = \frac{k}{2}.$$

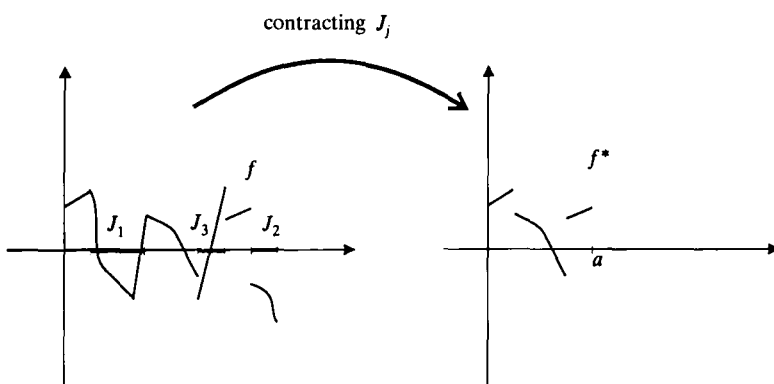

Figure 6. Contracting the J_k 's

Note that we have removed subintervals from $[0, 1]$ over which the integrals were a nonnegative integer multiple of $-\frac{1}{2}$. Now apply the $1/k$ version of the chord theorem to this pair. As before, we get a subinterval I^* of $[a, b]$ such that f^* and g^* have equal integrals over I^* , and the common value of these integrals is $\pm \frac{1}{2}$. Let I be the subinterval of $[0, 1]$ that corresponds to I^* under the contraction when we removed the intervals J_k . If the integral over I^* of f^* and g^* is $-\frac{1}{2}$, then I cannot contain J_1 by the maximality of J_1 , so I and J_1 are disjoint. For the same reason I cannot contain J_2 , or J_3 , etc. Thus, I is a subinterval disjoint from every J_k over which both f and g have integral $-\frac{1}{2}$, which is impossible, since the system $\{J_k\}_{k=1}^m$ is maximal.

Therefore, the integral of f^* and g^* over I^* is $\frac{1}{2}$. But then I can contain only J_k 's over which the integral of f and g is zero, for otherwise the integral over I would be zero or a positive multiple of $-\frac{1}{2}$, and this would contradict the maximality of the first J_k that is contained in I . Therefore, I contains only intervals J_k over which both f and g have integrals zero, so the integrals of f and g over I are the same as those of f^* and g^* over I^* , which is $\frac{1}{2}$. Therefore, this I is suitable.

5 THE CHESS KING-MOVING THEOREM. Suppose we color the squares of an $n \times n$ (chess) board with black and white arbitrarily. The chess king moving theorem (see [4], [5]) asserts that *a chess king can move either from the top row to the bottom row on black squares, or it can move from the leftmost column to the rightmost column on white squares.*

This statement is strong enough to prove the Brouwer fixed point theorem in two dimensions [5]. It also shows that in the following very entertaining game there is always a winner: two players B and W place alternately black and white disks on an $n \times x$ board. B 's aim is to connect the upper and lower edges of the board by his black disks, while W wants to connect the left and right sides of the board by his white disks. The game Hex is identical to this one, except that it is played on a rhomboid-shaped board of hexagons.

Now let us see how the chess king-moving theorem solves our problem. We again extend the functions f and g to the whole real line as 1-periodic functions, and, as we have already seen, it is sufficient to verify the existence of an interval I of length less than 1 somewhere on \mathbf{R} satisfying property (2). The function

$$\int_0^x f - \int_0^x g$$

attains its minimum at some point a . This implies that

$$\int_a^x f - \int_a^x g \geq 0$$

for all $x \geq a$. Therefore, by replacing f and g by $f^*(y) = f(a + y)$ and $g^*(y) = g(a + y)$, we can assume that

$$\int_0^y f - \int_0^y g \geq 0 \tag{10}$$

for all $y \geq 0$. Since the integral of both functions over an interval of length 1 is 1, this implies that for all $y \in [0, 1]$

$$\int_y^1 f - \int_y^1 g \leq 0. \tag{11}$$

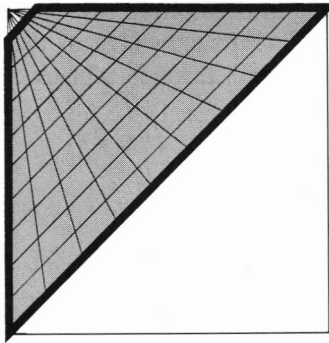

Figure 7. The squeezed chess board

Fix $\epsilon > 0$. Partition the triangle lying above the diagonal in the unit square by $n - 1$ rays emanating from the point $(0, 1)$ and by n lines parallel to the diagonal as illustrated in Figure 7. Discard the small triangles that contain the point $(0, 1)$. The remaining figure, partitioned into the (closed) pieces J_1, \dots, J_{n^2} , will be our chess board; it is a squeezed chess board, but the chess king-moving theorem is insensitive to the actual shape of the cells on the board. If n is sufficiently large, then for points (x_i, y_i) and (x_j, y_j) lying in neighboring cells J_i and J_j we have

$$\left| \int_{x_i}^{y_i} f - \int_{x_j}^{y_j} f \right| \leq \epsilon \quad \text{and} \quad \left| \int_{x_i}^{y_i} g - \int_{x_j}^{y_j} g \right| \leq \epsilon. \quad (12)$$

Now color a cell J black if there is a point $(x, y) \in J$ with

$$\left| \int_x^y f - \int_x^y g \right| \leq \epsilon; \quad (13)$$

all other cells remain white. If a cell J is white and is in the leftmost column, then by (10) we must have

$$\int_x^y f - \int_x^y g > \epsilon$$

for all $(x, y) \in J$, and conversely, (11) shows that if a white cell J is in the rightmost column (which means that it is on the upper edge of the unit square), then

$$\int_x^y f - \int_x^y g < -\epsilon$$

for all $(x, y) \in J$. Furthermore, in neighboring white cells the difference

$$\int_x^y f - \int_x^y g$$

can change by a quantity with absolute value at most 2ϵ (see (12)). Thus, by the definition of the coloring, a king cannot move on white cells from the leftmost column to the rightmost one. Therefore, it can move from the upper row to the lower one on black cells.

However, the cells in the upper row are around the point $(0, 1)$, so for points (x, y) in those cells the integral

$$\int_x^y f \quad (14)$$

is close to $\int_0^1 f = 1$, while cells in the bottom row contain diagonal points $(x, y) = (x, x)$ for which (14) is zero. Therefore, by (12), as the king moves from the upper row to the bottom row, it must pass through a black cell whose points satisfy

$$\left| \int_x^y f - \frac{1}{2} \right| \leq 2\epsilon,$$

and since this is a black cell, we also have

$$\left| \int_x^y g - \frac{1}{2} \right| \leq 5\epsilon.$$

What we have found is that for every $\epsilon = 1/n$, $n = 1, 2, \dots$ there are points $0 \leq x_n \leq y_n \leq 1$ such that

$$\left| \int_{x_n}^{y_n} f - \frac{1}{2} \right| \leq \frac{2}{n} \quad \text{and} \quad \left| \int_{x_n}^{y_n} g - \frac{1}{2} \right| \leq \frac{5}{n}.$$

From here the rest is standard: select a subsequence N_1 of the natural numbers for which $\{x_n\}_{n \in N_1}$ converges to some x and at the same time $\{y_n\}_{n \in N_1}$ converges to some y . Then the preceding inequalities easily yield

$$\int_x^y f = \int_x^y g = \frac{1}{2},$$

which is what we had to verify.

6 THE WINDING NUMBER THEOREM. Let $\Delta \subset \mathbf{R}^2$ be the unit disk and let $V: \Delta \rightarrow \mathbf{R}^2$ be a continuous vector field that does not vanish on the circumference. If the winding number of V on the circumference is not zero, then V must vanish somewhere on Δ [2, pp. 134–135] or [1, pp. 255–257].

The term “vector field” comes from the fact that for every point P of Δ the value $V(P)$ is a two dimensional vector, and we can think of placing the tail of this vector at the point P (see Figure 8). As we move around the circumference, the

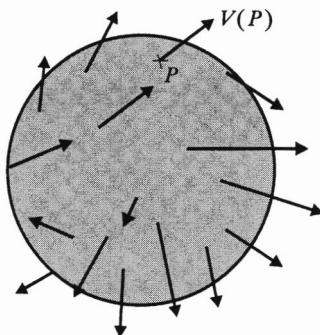

Figure 8. Vector field

vector $V(\cos t, \sin t)$ is not zero and depends continuously on $t \in [0, 2\pi]$, so the angle it forms with the positive half axis is also a continuous function $A(t)$; we do not take the angle modulo 2π . For the parameter value $t = 2\pi$ we arrive back again at the point $(0, 1)$ associated with $t = 0$, so the vectors corresponding to these two parameter values are the same. Thus, $A(2\pi)$ must be equal to $A(0)$ plus a positive multiple of 2π . The winding number of V is $(A(2\pi) - A(0))/2\pi$, which is an integer.

The winding number theorem can be proved as follows: If the field does not vanish on Δ , then the winding number on circles $\{|z| = a\}$ changes continuously with a . Since it is always an integer, it is constant. However, this constant is not zero for $a = 1$ by assumption, and it is clearly zero for $a = 0$. This contradiction shows that the vector field must vanish somewhere.

Let us see how this theorem solves the problem (a solution by Attila Pór). Consider the subtriangle $D = \{(x, y) | 0 \leq x \leq y \leq 1\}$ lying above the diagonal of the unit square, and for $(x, y) \in D$ let

$$U(x, y) = \left(\int_x^y f - \frac{1}{2}, \int_x^y g - \frac{1}{2} \right).$$

We have to show that the vector field U vanishes somewhere in D .

Let $\varphi : \Delta \rightarrow D$ be a continuous one-to-one mapping between the unit disk and D (a homeomorphism). Then $V = U \circ \varphi$ defines a vector field on Δ , and the vanishing of U is equivalent to the vanishing of V . If V vanishes somewhere on the boundary, then we are done. If not, then V defines a continuous vector field on Δ that does not vanish on the boundary. If its winding number is not zero, the winding number theorem ensures that V vanishes somewhere on Δ . Since φ carries the vectors from the field U into the vectors of the field V , we can work directly on D , where the winding number of the field U is defined as the winding number of V .

On the diagonal of the triangle the vector field U has the constant value $(-\frac{1}{2}, -\frac{1}{2})$. Therefore, on this part of the boundary the field U does not rotate. If $0 \leq x \leq 1$, then (1) shows that

$$U(0, x) + U(x, 1) = (0, 0),$$

i.e.,

$$U(x, 1) = -U(0, x).$$

It follows that the total winding of the field along the horizontal side of D is the same as the total winding along the vertical side (both travelled, say, in counter-clockwise direction), because the corresponding angles always differ by π . Furthermore, since $U(0, 0) = (-\frac{1}{2}, -\frac{1}{2})$, while $U(0, 1) = (\frac{1}{2}, \frac{1}{2})$, the angles of these two vectors must differ by $2k\pi + \pi$ for some integer k . Therefore, the winding number of the field U along the boundary of D is

$$2(2k\pi + \pi)/2\pi = 2k + 1 \neq 0,$$

and this is what we needed to prove.

7 THE JORDAN CURVE THEOREM. The Jordan curve theorem [8] states that *any continuous simple closed curve on the plane divides the plane into two connected components.*

To our problem we give a solution, due to Tamás Fleiner, that relies on an intuitively simple fact. We need the Jordan curve theorem to verify formally the intuitively obvious part.

Assume, as we may, that both f and g are step functions. Extend both f and g to \mathbf{R} as periodic functions with period 1, and let

$$F(x) = \int_0^x f \quad \text{and} \quad G(x) = \int_0^x g.$$

Then for all x we have $F(x + 1) = F(x) + 1$ and $G(x + 1) = G(x) + 1$. Furthermore, F and G are continuous, so for the points $a, b \in [0, 1]$ where $F - G$ attains

its maximum and minimum, respectively, we have for all x

$$A := F(a) - G(a) \geq F(x) - G(x) \quad \text{and}$$

$$B := F(b) - G(b) \leq F(x) - G(x).$$

The curve $\gamma(x) = (F(x), G(x))$ is a union of line segments. We verify that there is a $y \in [0, 1]$ and an $y - 1 < x < y$ such that $\gamma(y) = \gamma(x) + (\frac{1}{2}, \frac{1}{2})$. If $A = B$, then $F \equiv G$ and we have the trivial case $f \equiv g$. If $A \neq B$, then by interchanging the role of F and G , respectively, we may assume $a < b$. The curve $\gamma(x)$ lies within the strip S determined by the lines $x - y = A$ and $x - y = B$, and the portion of γ corresponding to the parameter values $x \in [a, b]$ connects the two bounding lines of this strip (see Figure 9). By replacing a by the largest value

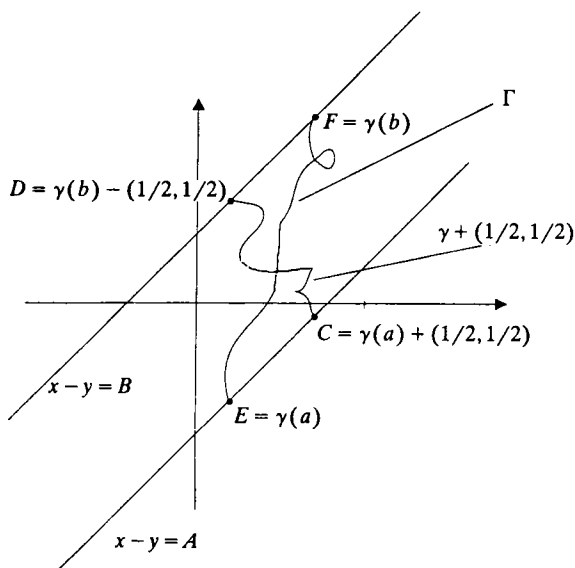

Figure 9. The two paths CD and EF have to intersect

$a' < b$ for which $\gamma(a')$ belongs to the lower bounding line $x - y = A$, and then replacing b by the smallest $a' < b'$ for which $\gamma(b')$ belongs to the upper bounding line $x - y = B$, we can also suppose that the curve

$$\Gamma := \{\gamma(x) \mid a \leq x \leq b\}$$

lies strictly within the strip S except for its two endpoints. Now the points $C := \gamma(a) + (\frac{1}{2}, \frac{1}{2})$ and $D := \gamma(b) - (\frac{1}{2}, \frac{1}{2})$ cannot be connected by a continuous piecewise-linear path that does not leave S and does not intersect the curve Γ (look at the X -shaped figure in Figure 9). However, $\gamma(b) - (\frac{1}{2}, \frac{1}{2})$ is $\gamma(b - 1) + (\frac{1}{2}, \frac{1}{2})$, so the two points C and D do lie on the curve $\gamma(x) + (\frac{1}{2}, \frac{1}{2})$, $b - 1 < x < a$. Hence, there must be a point of intersection, i.e., there is an $x \in (b - 1, a)$ and a $y \in (a, b)$ such that $\gamma(y) = \gamma(x) + (\frac{1}{2}, \frac{1}{2})$. Furthermore, $b - 1 < x < a < y < b$, so $y - 1 < x < y$. By the definition of the curve γ , $F(y) - F(x) = \frac{1}{2}$ and $G(y) - G(x) = \frac{1}{2}$, i.e., both f and g have integral $\frac{1}{2}$ on the interval $[x, y]$. The rest of the argument is now the same as in Section 4: if $x \geq 0$, then the interval $I = [x, y]$ satisfies the requirements. If, however, $x < 0$, then the interval $I = [y, x + 1]$ is

suitable, for then

$$\int_I f = F(x+1) - F(y) = 1 + F(x) - F(y) = 1 - \frac{1}{2} = \frac{1}{2},$$

and a similar calculation shows that the integral of g over I is again $\frac{1}{2}$.

This proof is based on the fact that two curves in S , one connecting the points E and F and the other connecting the points C and D , must intersect. This is intuitively clear, but for a formal verification we invoke the Jordan curve theorem stating that any continuous simple closed curve τ on the plane divides the plane into two connected components. By a continuous simple closed curve we mean a continuous function $\tau: [0, 1] \rightarrow \mathbf{R}^2$ such that $\tau(0) = \tau(1)$, and for $0 \leq x < y < 1$ we have $\tau(x) \neq \tau(y)$ (i.e., the points on the curve are all different, except for the starting and ending points). The statement itself means that $\mathbf{C} \setminus \tau = U \cup V$, where every point of U can be connected to any other point of U by a continuous piecewise-linear path lying in U , and similarly for V . Furthermore, no two points lying in U and V , respectively, can be connected by such a path not intersecting τ . How do we know that we cross from one component (U or V) to another one? Well, this is certainly the case if we move along a segment that intersects τ in exactly one point, and is perpendicular to a segment of τ .

The fact that Γ has a non-empty intersection with any continuous piecewise-linear path connecting C and D within S now can be verified as follows. By removing loops from Γ we can assume that it is a simple curve. Then consider the curve τ described in Figure 10. Moving along the segment CH we get from one connected

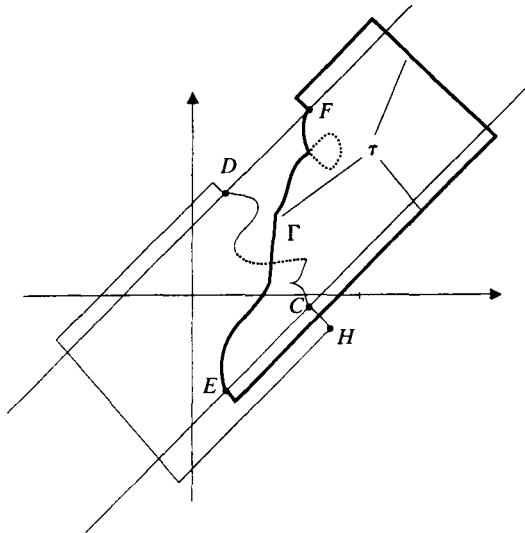

Figure 10. The two paths CD and EF must intersect

component of $\mathbf{C} \setminus \tau$ to the other one, so the points C and D are in different components of $\mathbf{C} \setminus \tau$. Therefore, any continuous piecewise-linear path connecting C and D lying in S (e.g., $\{\gamma(x) | b-1 < x < a\}$) must intersect τ . But $\tau \cap S = \Gamma$, so every such path must intersect Γ itself, which is what we needed to prove.

We have presented several solutions to our problem that were based on some known theorems from planar geometry and topology. Some of these theorems are

also interrelated and it is easy to see that the statement in our problem is actually equivalent to at least one of them, namely to the chord theorem.

ACKNOWLEDGMENT. The author acknowledges partial support by the National Science Foundation (DMS-9415657) and by the Hungarian Academy of Sciences (96-328).

REFERENCES

1. M. K. Agoston, Algebraic Topology, *Pure and Applied Mathematics* 32, Marcell Dekker, Inc., New York, Basel, 1976
2. D. W. Blakett, *Elementary Topology*, Academic Press, Inc., New York, 1982.
3. *Contests in Higher Mathematics*, 1949-1961, Akadémiai Kiadó, Budapest, 1968.
4. *Delta; Mathematical, Physical and Astronomical Popular Monthly* 115 / 7 (1983), Problem 235, p. 7.
5. D. Gale: The game of Hex and the Brouwer fixed-point theorem, *Amer. Math. Monthly* 86 (1979) 818-827.
6. J. E. Goodman, J. Pach, and C. K. Yap, Mountain climbing, ladder moving and the ring-width of a polygon, *Amer. Math. Monthly* 96 (1989) 494-510.
7. J. P. Huneke, Mountain Climbing, *Trans. Amer. Math. Soc.* 139 (1969) 383-391.
8. K. Kuratowski, *Introduction to set theory and topology*, International Series of Monographs on Pure and Applied Mathematics 13, Pergamon Press, New York, 1961.
9. J. V. Whittaker, A mountain climbing problem, *Can. J. Math.* 18 (1966) 873-887.

VILMOS TOTIK was born in 1954 in Hungary. He is a professor at the Bolyai Institute, Szeged, Hungary and also at the University of South Florida, Tampa. He is a member of the Hungarian Academy of Sciences. He has (co)authored four research monographs: *Moduli of Smoothness*, *General Orthogonal Polynomials*, *Logarithmic Potentials with External Fields*, and *Weighted Approximation with Varying Weights*. His loves are his family (Veronika, Orsolya, Zoltán), his profession (approximation theory, orthogonal polynomials, potential theory), sports (soccer, tennis, table tennis), and any other normal activities (gardening, carpentry, ...).

*Bolyai Institute, Szeged, Aradi v. tere, 1, 6720, HUNGARY and
University of South Florida, Tampa, FL 33620
totik@math.usf.edu*

From the MONTHLY 50 years ago ...

The following reports of Summer Sessions to be held in 1924 have been received.

University of Chicago, first term, June 16 to July 23; second term, July 24 to August 29. In addition to the usual courses in College algebra, Plane analytic geometry, and Calculus, the following advanced courses are announced: By Professor G. A. Bliss: Functions of a real variable; Thesis work in analysis. By Professor L. E. Dickson: Theory of Numbers, I; Thesis work in number theory. By Professor H. E. Slaught: Elliptic integrals; Differential equations. By Professor M. Fréchet: Theory of abstract sets; Theory of probability. By Professor E. T. Bell: General theory of numbers; Theory of equations. By Professor F. R. Moulton: Functions of infinitely many variables; Analytic mechanics, II. By Professor E. P. Lane: Synthetic projective geometry. By Doctor Mayme L. Logsdon, Introduction to higher algebra.

... Vol. 31 (1924) 211